

# RIDGEBACK™

## Omnidirectional Development Platform

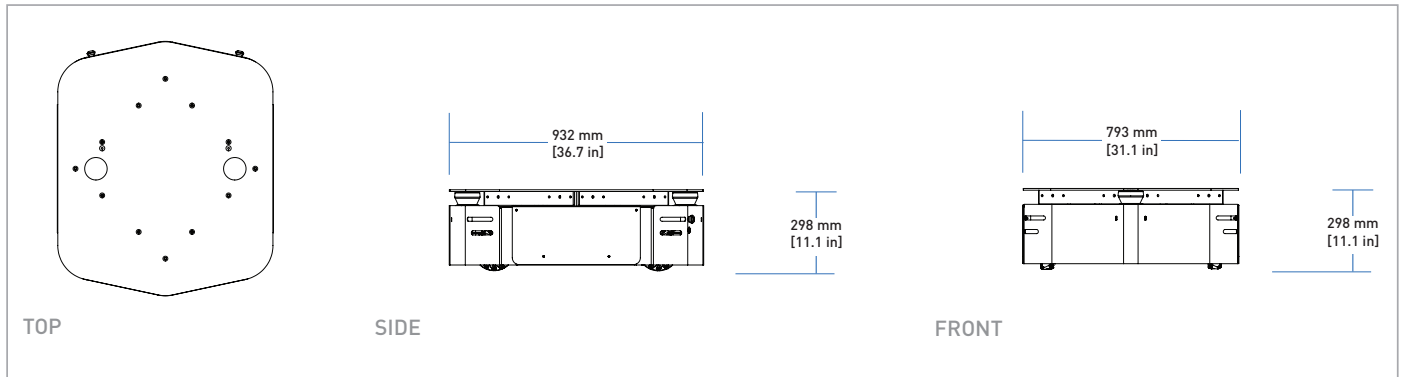

## TECHNICAL SPECIFICATIONS

SIZE AND WEIGHT	
EXTERNAL DIMENSIONS	932 x 793 x 298 mm (L x W x H)
WEIGHT	125 kg
OBSTACLE CLEARANCE	18 mm
SPEED AND PERFORMANCE	
MAX PAYLOAD	100 kg
MAX SPEED	1.1 m/s
DRIVE CONFIGURATION	4 Independently driven omni-directional wheels
OPERATING ENVIRONMENT	Indoor
BATTERY AND POWER SYSTEM	
BATTERY CHEMISTRY	Marine Grade AGM Sealed Lead Acid
CAPACITY	24 V 100 Ah
OPERATING TIME	8 Hours max
CHARGE TIME	5 Hours approx
USER POWER	5 V, 12 V, 24 VDC (fused at 10A each), optional 120 VAC
DRIVE POWER	2000 W peak, 800 W continuous
INTERFACING AND COMMUNICATION	
CONTROL MODES	Kinematic control (forward, sideways, rotation), individual wheel velocities
FEEDBACK	Battery, gyroscope and accelerometer
COMMUNICATION	Ethernet, USB 3.0, RS 232
INCLUDED ACCESSORIES	Onboard computer, laser, gyroscope
DRIVERS AND APIs	ROS Indigo, Gazebo, navigation support, MoveIt!

Contact us today for pricing and a free 30 minute technical assessment: **1-800-301-3863**