



SPEC SHEET 2012



MECHANICAL

TOTAL WEIGHT	5,7 kg
MAXIMUM PAYLOAD	1,5 kg mid-range 1,0 kg full extension
MAXIMUM REACH	90 cm
GEAR SYSTEM	
<i>Type</i>	Harmonic Drive
<i>Resolution</i>	1:100
<i>Back drivability</i>	When shutdown
ABSOLUTE POSITION TOLERANCE	8 mm
RELATIVE POSITION TOLERANCE	1,6 mm
MAXIMUM LINEAR ARM SPEED	15 cm/s (Cartesian)
AMBIENT TEMPERATURE	0°C to 30°C
WATER RESISTANCE	IPX2 rating

ELECTRONIC

UTILIZATION VOLTAGE	18VDC to 29VDC
AVERAGE CURRENT (NORMAL USE)	1,7 A
AVERAGE POWER (NORMAL USE)	40 W
CONTROL SYSTEM FREQUENCY	100 Hz
CPU	270 Mhz
USB 2.0	
CANBUS	
<i>Transfer speed</i>	1 Mb/sec
SLIP RING	
<i>Location</i>	1 in every joint
EXPANSION CARD	
<i>Connector</i>	2 expansion cards connectors
<i>Protocol</i>	SPI
<i>2 expansion wires through external joystick connector</i>	
<i>2 expansion wires through internal of the arm</i>	

FIRMWARE

EACH AXIS CONTROLLED INDEPENDENTLY

REDUNDANT SECURITY ON EACH AXIS / FINGERS

REDUNDANT ERROR CHECK IN JOINTS AND IN CONTROL SYSTEM

POSITION AND ERROR CALCULATION EVERY 0.01 SECOND

SINGULARITY AVOIDANCE SYSTEM

CARTESIAN AND ANGULAR TRAJECTORY CONTROL

ACTUATORS - Large actuator

QUANTITY	3
DIMENSIONS	
<i>Diameter</i>	74.5 (+0.00 / -0.030) mm
<i>Height</i>	67mm max
<i>Input fixation type</i>	8X M4 screws (5mm deep)
<i>Output fixation type</i>	8X M4 screws (5mm deep)
TOTAL WEIGHT	0.64 Kg +/-2%
ABSOLUTE POSITION	+/- 0.5 degree
RELATIVE POSITION	+/- 0.05 degree
MOTOR TYPE	Brushless DC motor
NUMBER OF TURNS	+/- 13.5 turns
TEMPERATURE <i>Maximum</i>	75°C continuous
VELOCITY <i>Maximum</i>	8 RPM
COMMAND/SEC <i>Maximum</i>	48 °/sec
UTILIZATION VOLTAGE	18VDC to 29VDC
TORQUE	
<i>Continuous</i>	15 Nm
<i>Peak</i>	26 Nm

ACTUATORS - Small Joint

QUANTITY	3
DIMENSIONS	
<i>Diameter</i>	58 (+0.00 / -0.030) mm
<i>Height</i>	69mm max
<i>Input fixation type</i>	6X M3 screws (5mm deep)
<i>Output fixation type</i>	6X M3 screws (5mm deep)
TOTAL WEIGHT	0.39Kg +/- 2%
ABSOLUTE POSITION	+/- 0.5 degree
RELATIVE POSITION	+/- 0.075 degree
MOTOR TYPE	Brushless DC motor
NUMBER OF TURNS	+/- 13.5 turns
TEMPERATURE <i>Maximum</i>	75°C continuous
VELOCITY <i>Maximum</i>	10 RPM
COMMAND/SEC <i>Maximum</i>	60 °/sec
UTILIZATION VOLTAGE	18VDC to 29VDC
TORQUE	
<i>Continuous</i>	4 Nm
<i>Peak</i>	7 Nm

ACTUATORS - Finger actuator

QUANTITY	3
MOTOR TYPE	Brushless DC motor
TEMPERATURE <i>Maximum</i>	75°C
VELOCITY <i>Maximum</i>	600 RPM
COMMAND/SEC <i>Maximum</i>	30 units/sec
UTILIZATION VOLTAGE	18VDC to 29VDC
TORQUE	
<i>Continuous</i>	15mNm
<i>Peak</i>	30mNm

SENSORS

CURRENT

Location

1 in every actuators

HALL EFFECT

Location

1 in every actuators

ABSOLUTE POSITION

Location

1 in every actuators

TEMPERATURE

Location

1 in every actuators

ACCELEROMETER

Location

XYZ in base (+/- 3g)

GRIPPER

FINGERS

Quantity

3

Actuating system

Under actuated

Actuators

1/finger

Sensors

1 current sensor/actuator

1 temperature sensor/actuator

1 hall effect sensor/actuator

Tactile sensors

No

API AND SOFTWARE

API*

Compatibility

Port

Programming languages

Functions

Windows & Linux Ubuntu

USB 2.0

C# (C++ blabla)

Cartesian control (speed or position)

Angular control (speed or position)

Data access

General configuration

Control configuration

Diagnostic tools

JACOSOFT

Compatibility

Port

Tools

Windows

USB 2.0

General Information

Configuration

Protection Zones

Trajectory

Diagnosis

* Please refer to the JACO API Documentation guide to get a complete description of the API functionalities.

DIMENSIONS

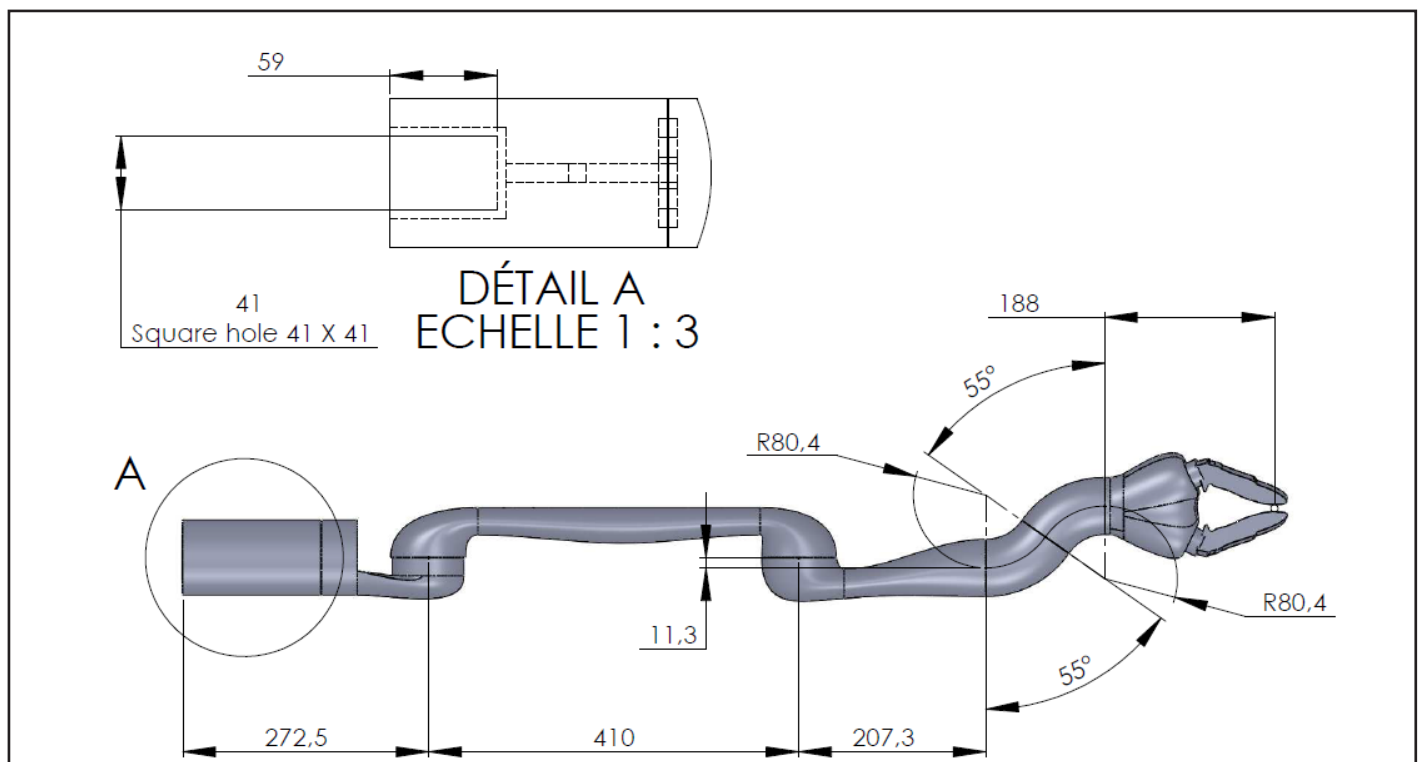



355 rue Peel #301
Montreal (Quebec), Canada
H3C 2G9

514-277-3777
info@kinovarobotics.com